

2380	1920	426

14АБ / 3231

Комплектовочная ведомость / Set package sheet

Упак/ Package	Наименование	Description	Цвет детали/ Décor	Размер / Size, mm	Кол-во/ Quantity	№
1	Боковина левая	Side left	White	1868x406	1	4
	Боковина правая	Side right	White	1868x406	1	5
	Боковина	Side	Craft gold	304x406	1	1
	Крыша верх	Top upper	Craft gold	550x406	1	8
	Крыша низ	Top lower	Craft gold	550x406	1	9
	Планка	Plank	Craft gold	420x100	1	18
	Створка	Door	White	196x446	1	22
2	Крыша верх	Top upper	Craft gold	1380x406	1	11
	Крыша низ	Top lower	Craft gold	1380x406	1	12
	Крыша	Top	White	450x406	2	7
	Вязка	Connecting element	Craft gold	416x406	4	13
3	Створка	Door	Craft gold	1376x342	1	23
	ХДФ	Back element	White	1380x332	1	28
	Задник	Back element	Craft gold	1336x196	1	17
	Боковина левая	Side left		1336x337	1	2
	Боковина правая	Side right		1336x337	1	3
	Планка	Plank		1250x100	1	19
	Планка	Plank		1252x100	2	20
4	Крыша	Top	Craft gold	1250x337	1	10
	Вязка	Connecting element		1234x321	1	15
	Вязка	Connecting element		404x321	3	14
	Боковина	Side		304x406	2	1
	Крыша	Top		420x337	1	6
	Задник	Back element		1234x337	1	16
5	Створка	Door	White	550x446	2	21
	Фурнитура	Furniture/Cabinetry hardware	-	-	-	-
	ХДФ (клей)	Back element	White	379x446	2	24
	ХДФ (клей)	Back element		379x446	3	26
	ХДФ	Back element		550x332	1	27
	Створка	Door	Craft gold	546x342	1	24
6	Стеклополка	Glass shelves	transparent	414x396	1	29
	Стеклостворка	Glass		456x412	1	30

(PL) Instrukcja montażu

(CZ) Návod k montáži

(D) Montageanleitung

(GB) Assembly instruction

(F) Model d'emploi

(HU) Szerelési útmutató

(I) Istruzione di montaggio

(NL) Handleiding voor de montage



(RU) Инструкция по монтажу

(RO) Instrucțiuni de montare

(SK) Návod k montáži

(TR) Montaj talimatı

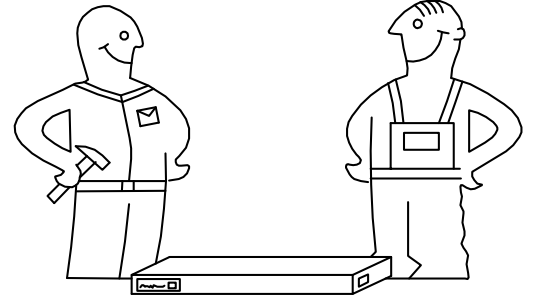
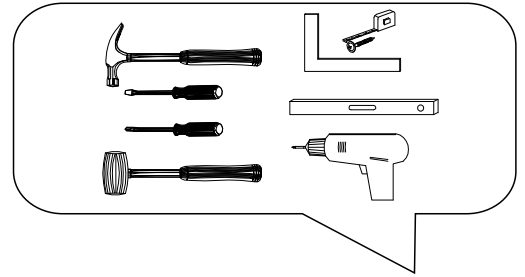



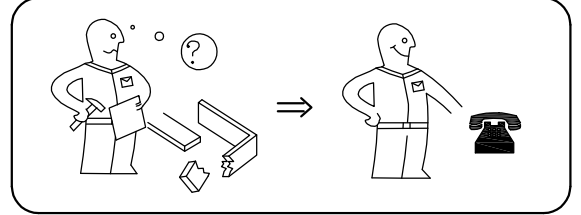
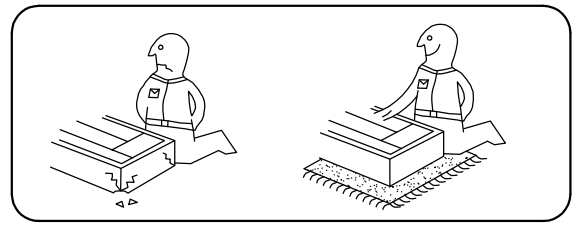



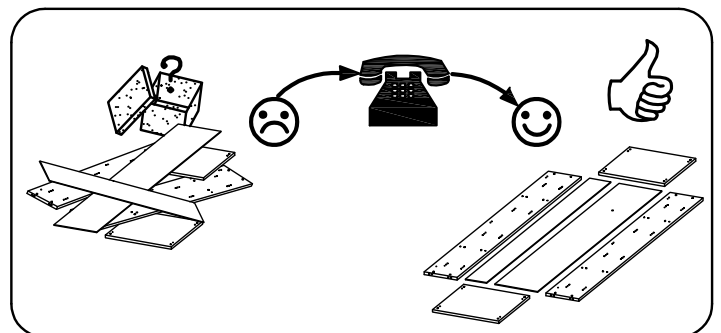
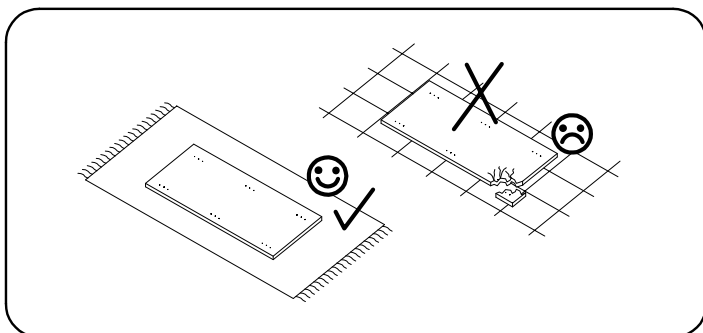
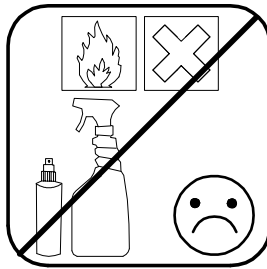
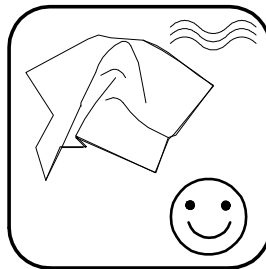
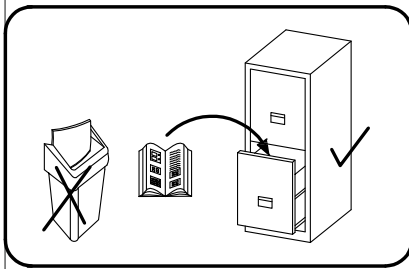

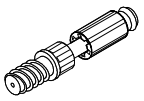

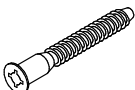

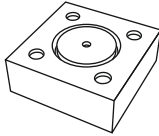

⚠ Uwaga • Upozornění • Achtung • Attention • Caution • Figyelem ⚠ Attenzione • Opgelet • Внимание • Atenție • Upozornenie • Dikkat	
PL	Czyszczenie należy wykonać wyłącznie za pomocą ściereczki lub lekko nawilżonego ręcznika. Nie stosować środków czyszczących do szorowania.
CZ	Čistění je nutné vykonávat výhradně pomocí utěrky nebo lehce navlhčeného ručníku. Nepoužívejte čističe obsahující abrazivní částice.
D	Bitte nur mit einem Staubtuch oder leicht feuchtem Lappen reinigen. Keine scheuernden Putzmittel verwenden.
GB	Please only clean with a duster or a damp cloth. Do not use any abrasive cleaners.
F	Le nettoyage se fait uniquement à l'aide d'un torchon ou d'une serviette légèrement mouillée.
HU	A tisztítás kizárólag törölőruha vagy enyhén nedvesített törölköző segítségével végezhető. Súroló hatású tisztítószereket nem szabad használni.
I	Pulire esclusivamente con un panno o un asciugamano umido.
NL	Reinig alleen met een stofdoek of een lichtjes vochtige doek. Gebruik geen schurende poetsmiddelen.
RU	Очищайте от пыли тряпкой или слегка влажной ветошью. Не допускается применение чистящих средств, не предназначенных для ухода за мебелью.
RO	Curățarea trebuie efectuată numai cu o cârpă sau cu un prosop ușor umezit. Nu utilizați agenți de curățare abrazivi.
SK	Čistení je nutné vykonávať výhradne pomocí utierky alebo ľahko zvlhnutým ručníkom. Nepoužívajte čistiace prostriedky obsahujúce abrazívne častice.
TR	Lütfen sadece bir toz bezilye veya hafif nemli yumuşak bir bezle siliniz. Aşındırıcı temizlik malzemeleri kullanmayınız.

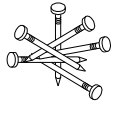

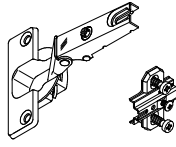
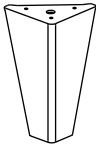
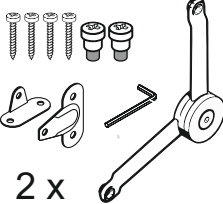
**Karta serwisowa • Servisní list • Service Karte • Service card • Carte de service • Szervizkártya
Scheda di servizio • Service kaart • Сервисная карта • Fisa service • Servisný list • Servis karti**

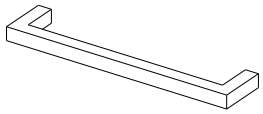

1		2		5	7x50	6	6,3x10,5	15	
									
65 x		65 x		29 x		20 x		1 x	
18	3,5x15	21		38		45		48	2x20
									
64 x		6 x		4 x		7 x		40 x	
61		91	Hinge A	135	H 125 mm	97		71	∅ 5 mm
									
4 x		10 x		4 x		2 x		16 x	
72	alder/white	73	alder/white	126	C42 128 mm				
									
15/14 x		57/8 x		4 x					

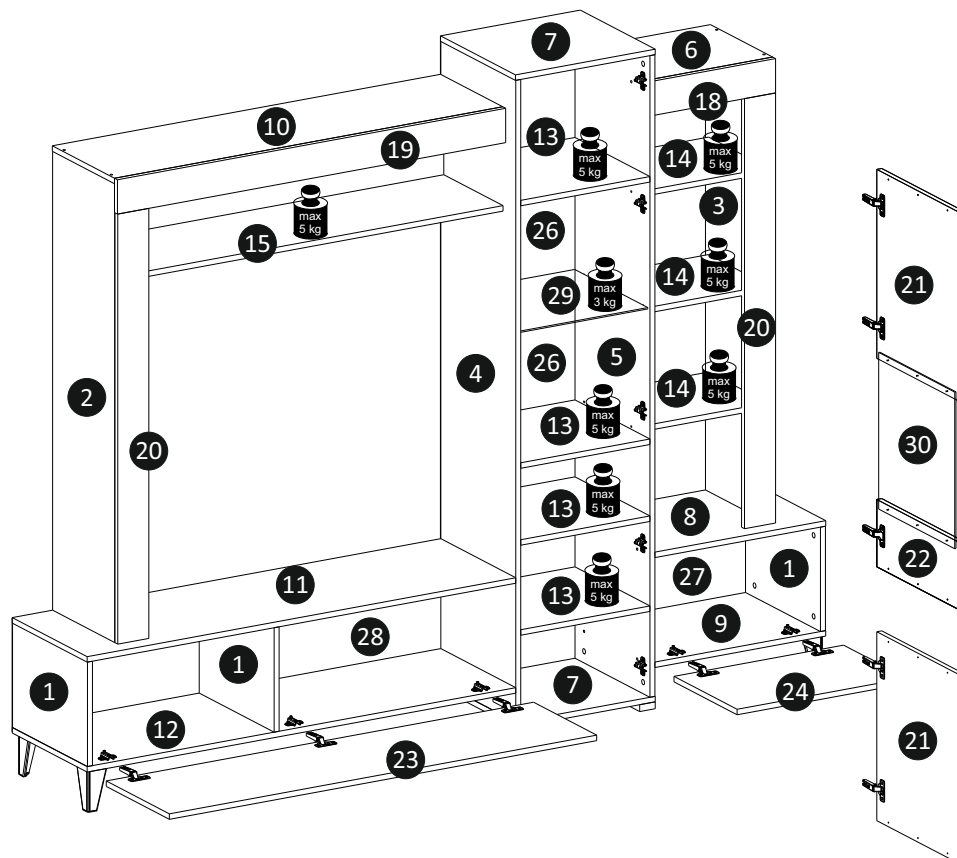

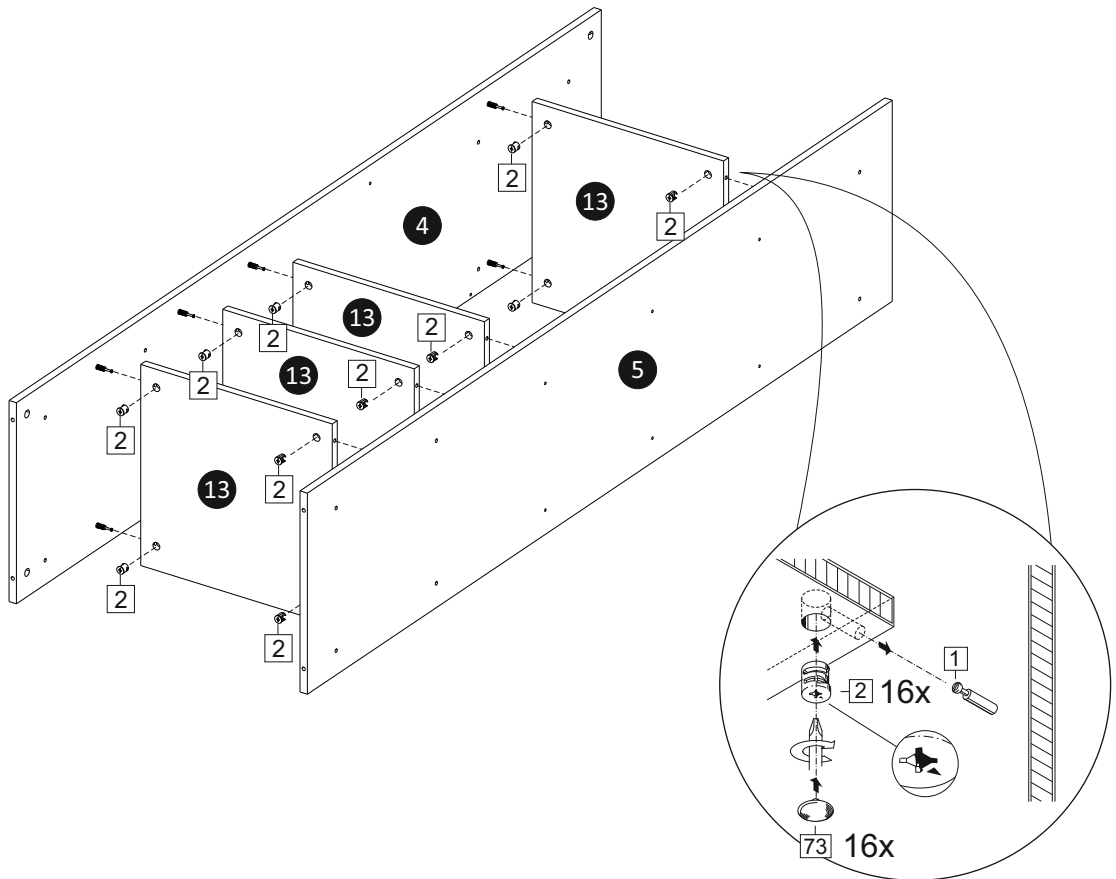
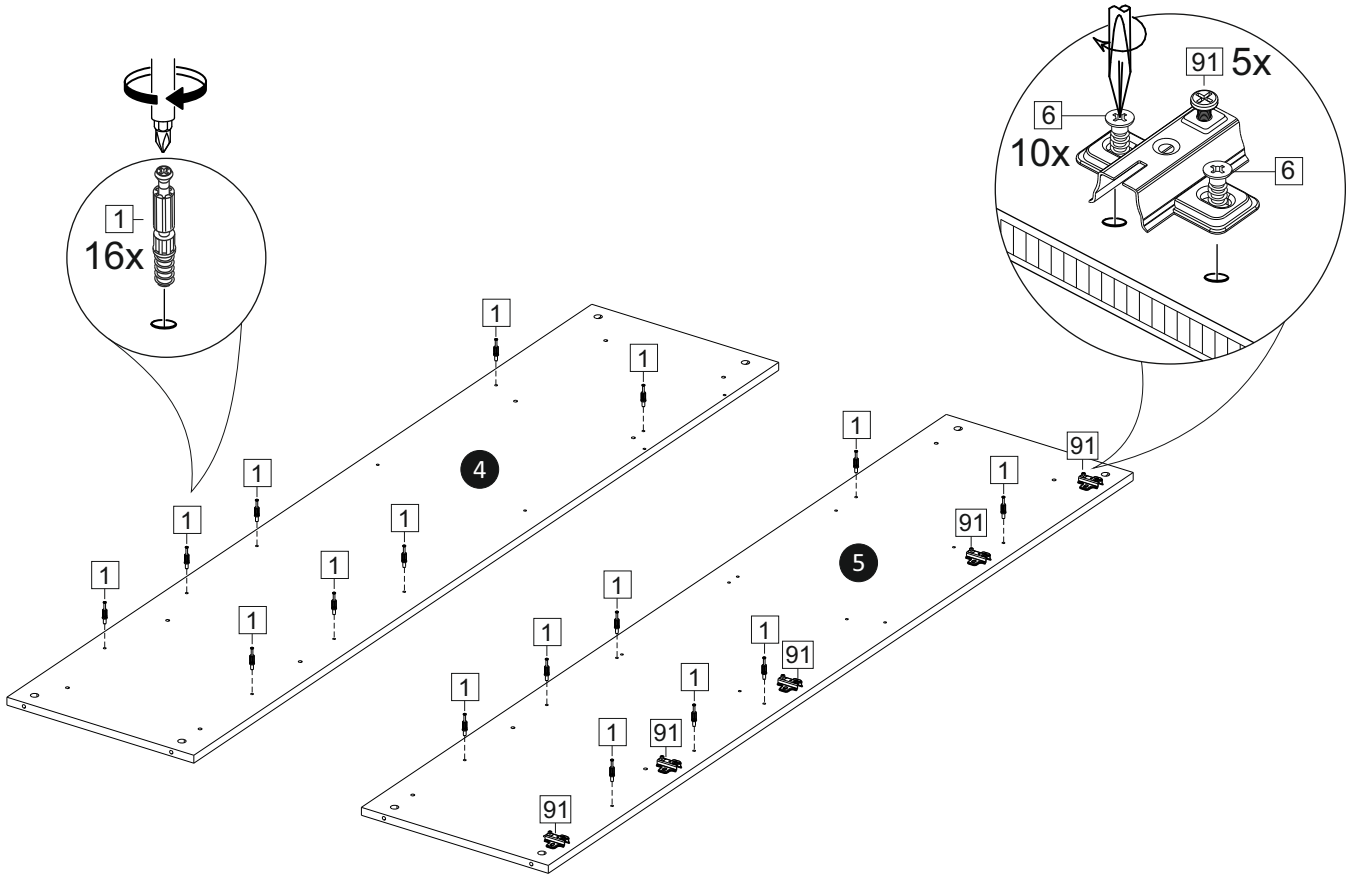

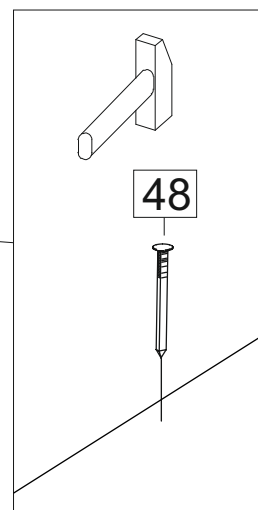
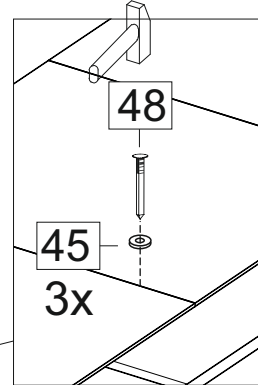
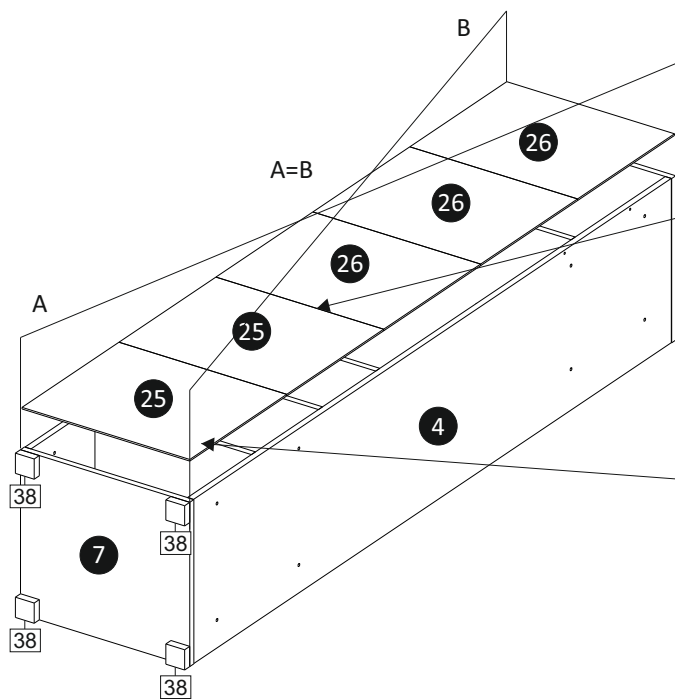
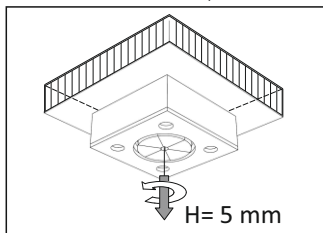
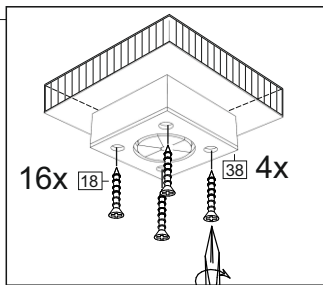
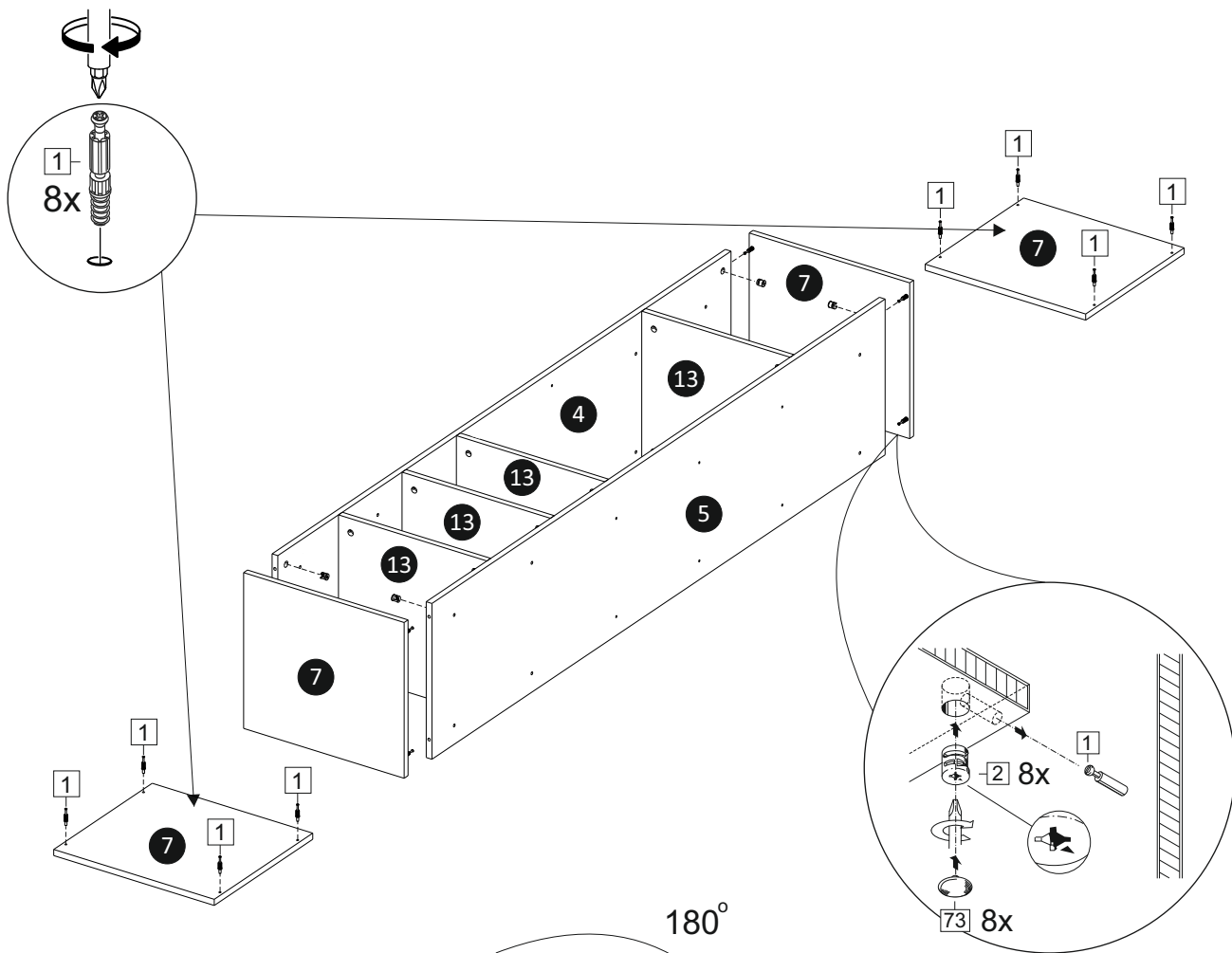

6

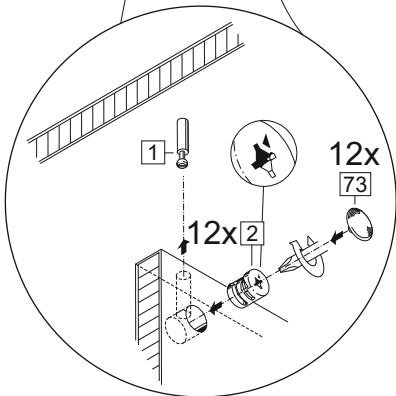
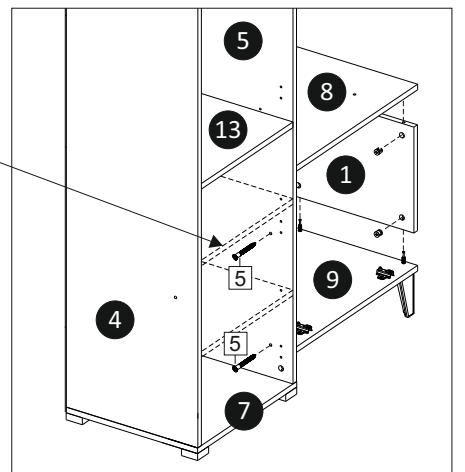
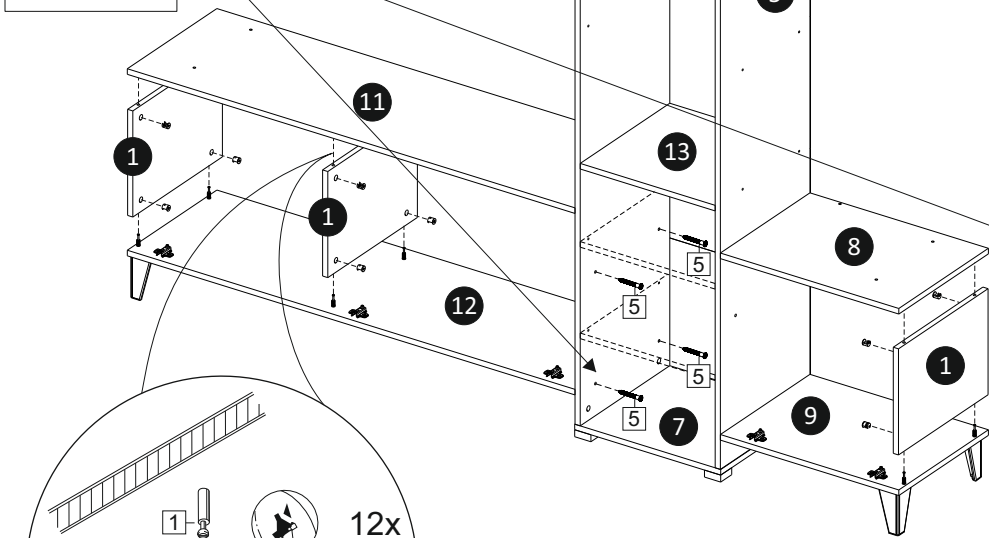
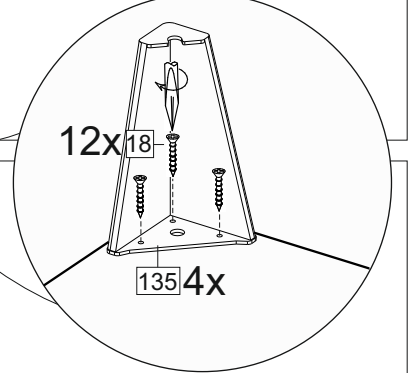
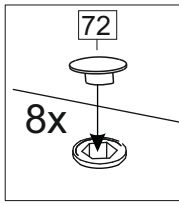
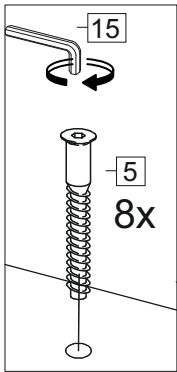
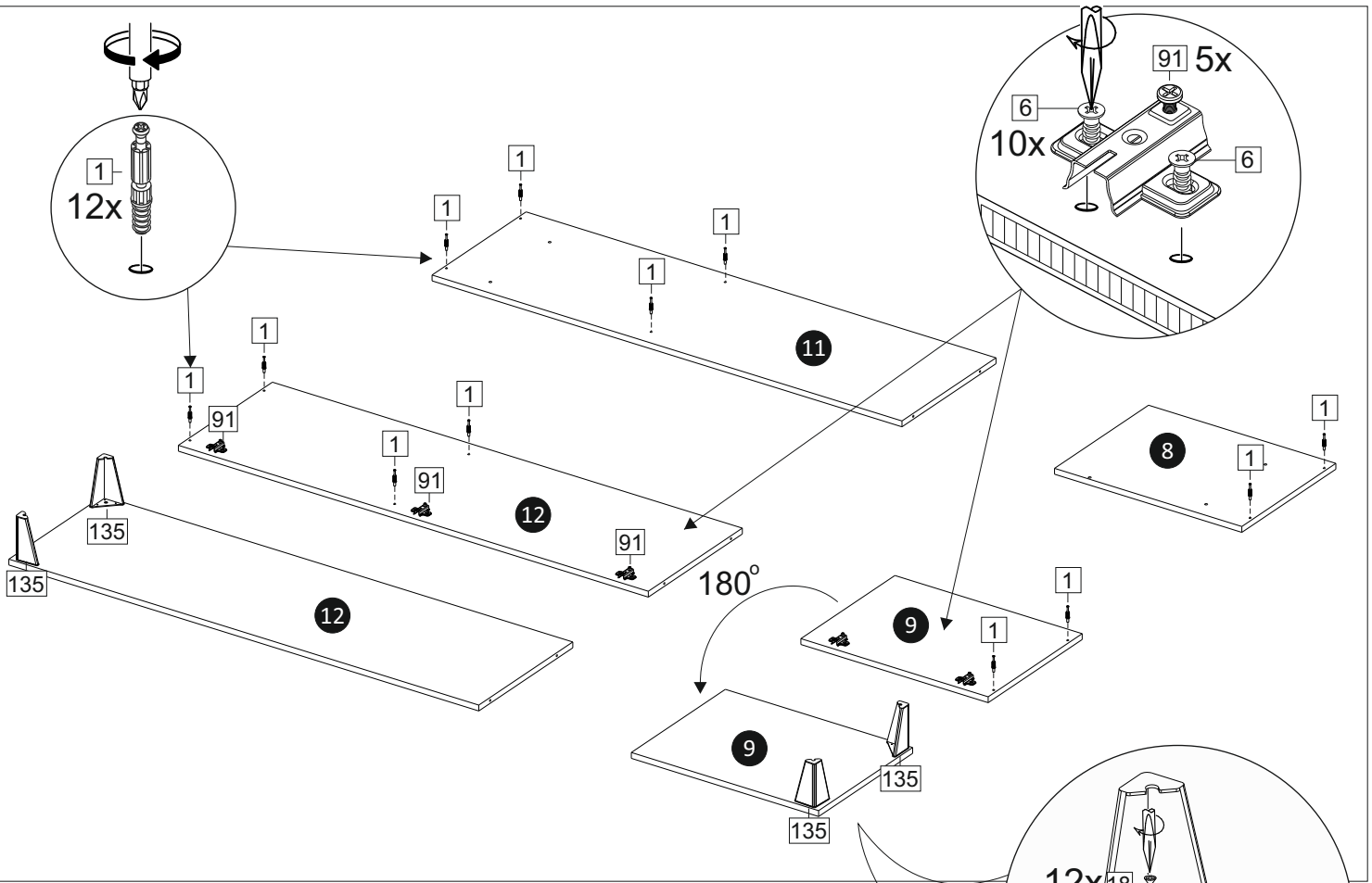

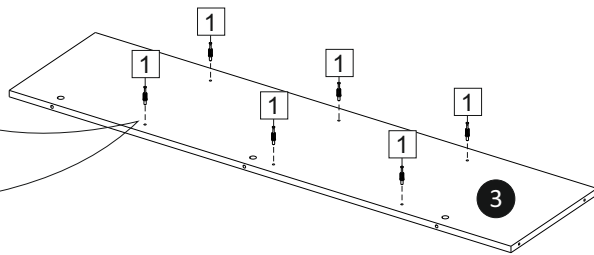
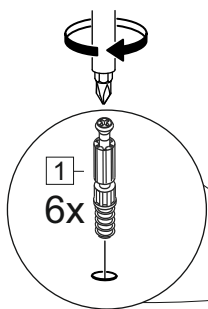
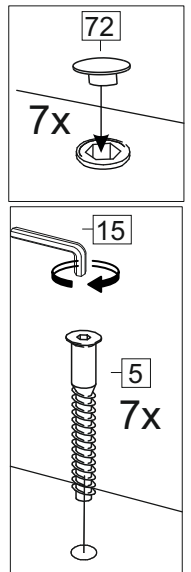
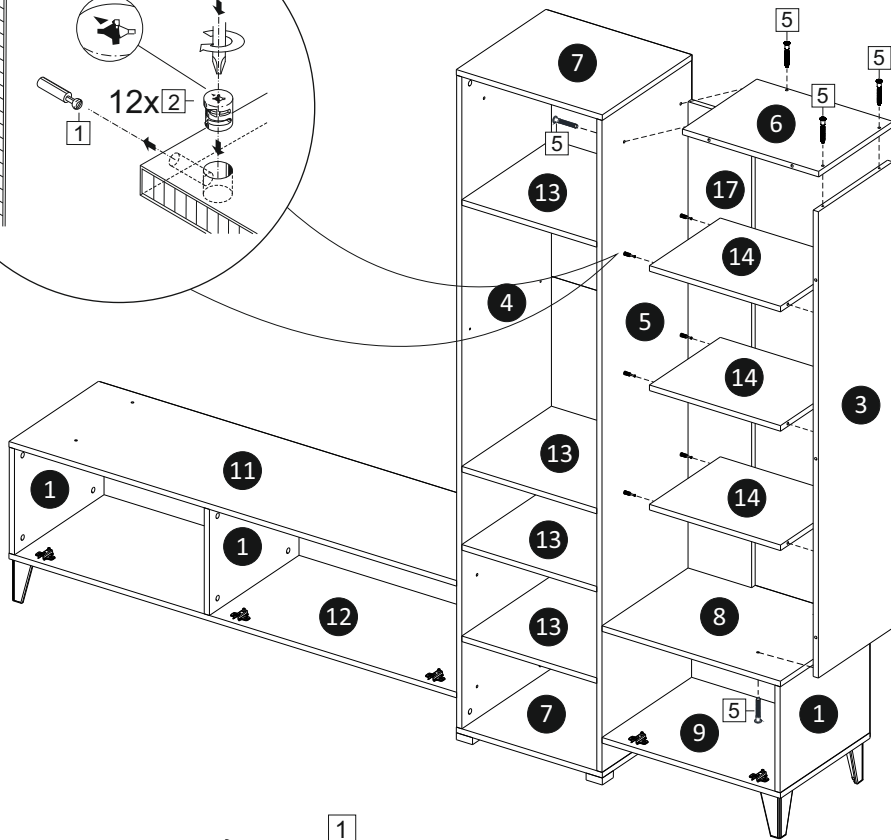
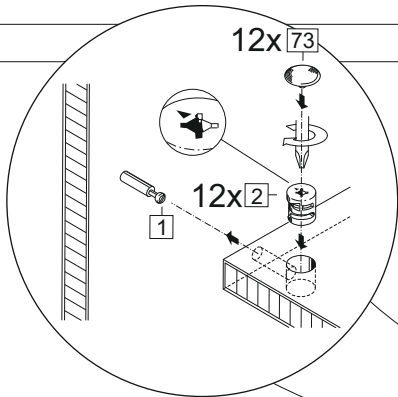
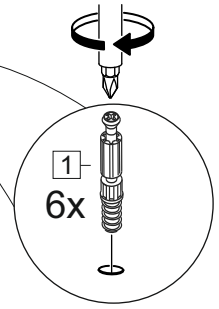
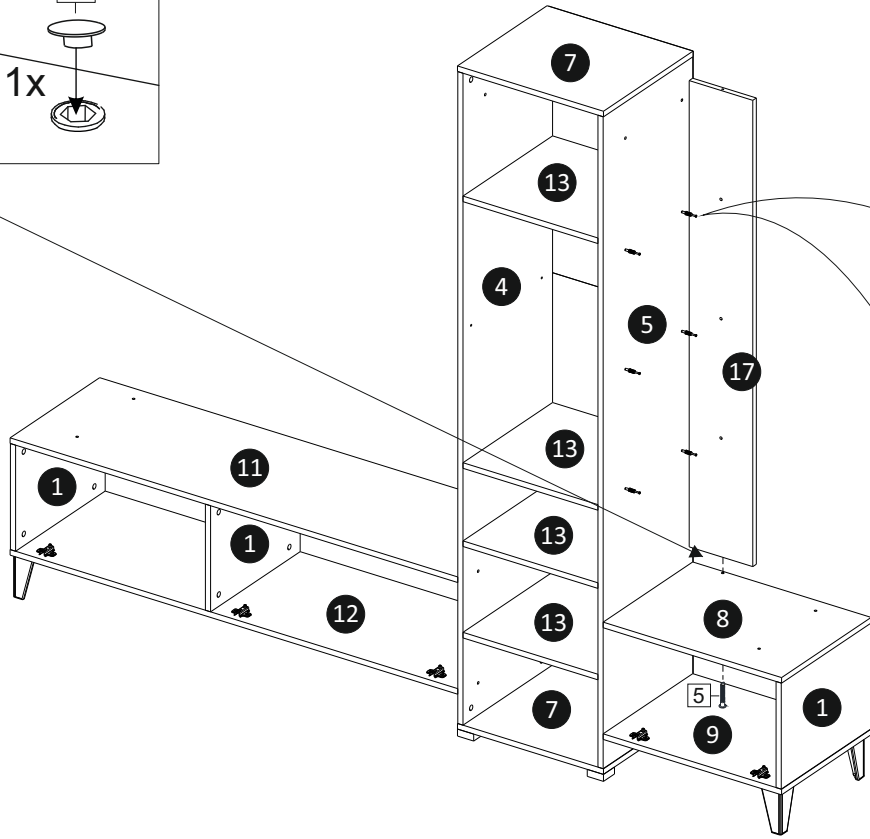
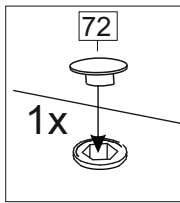
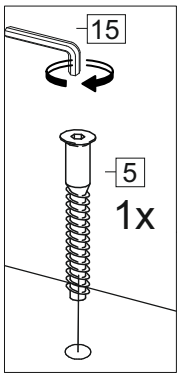

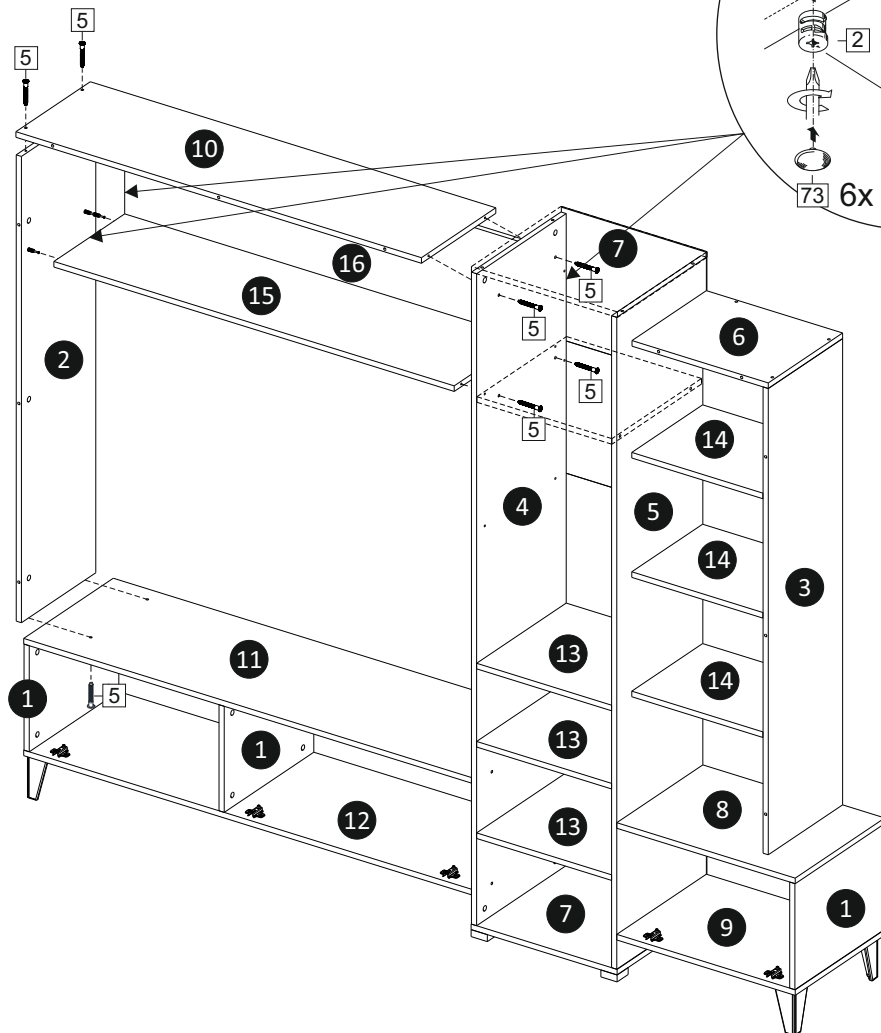
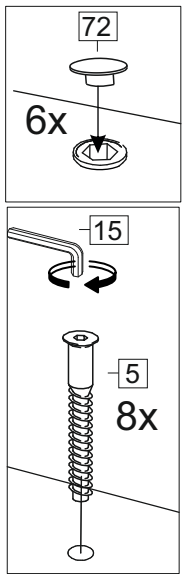
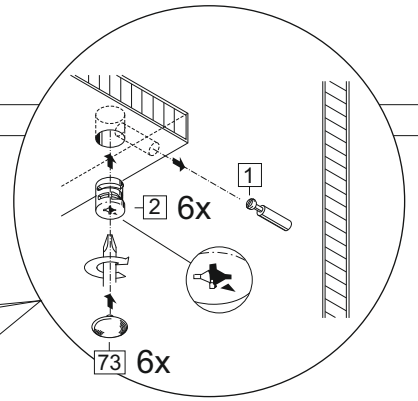
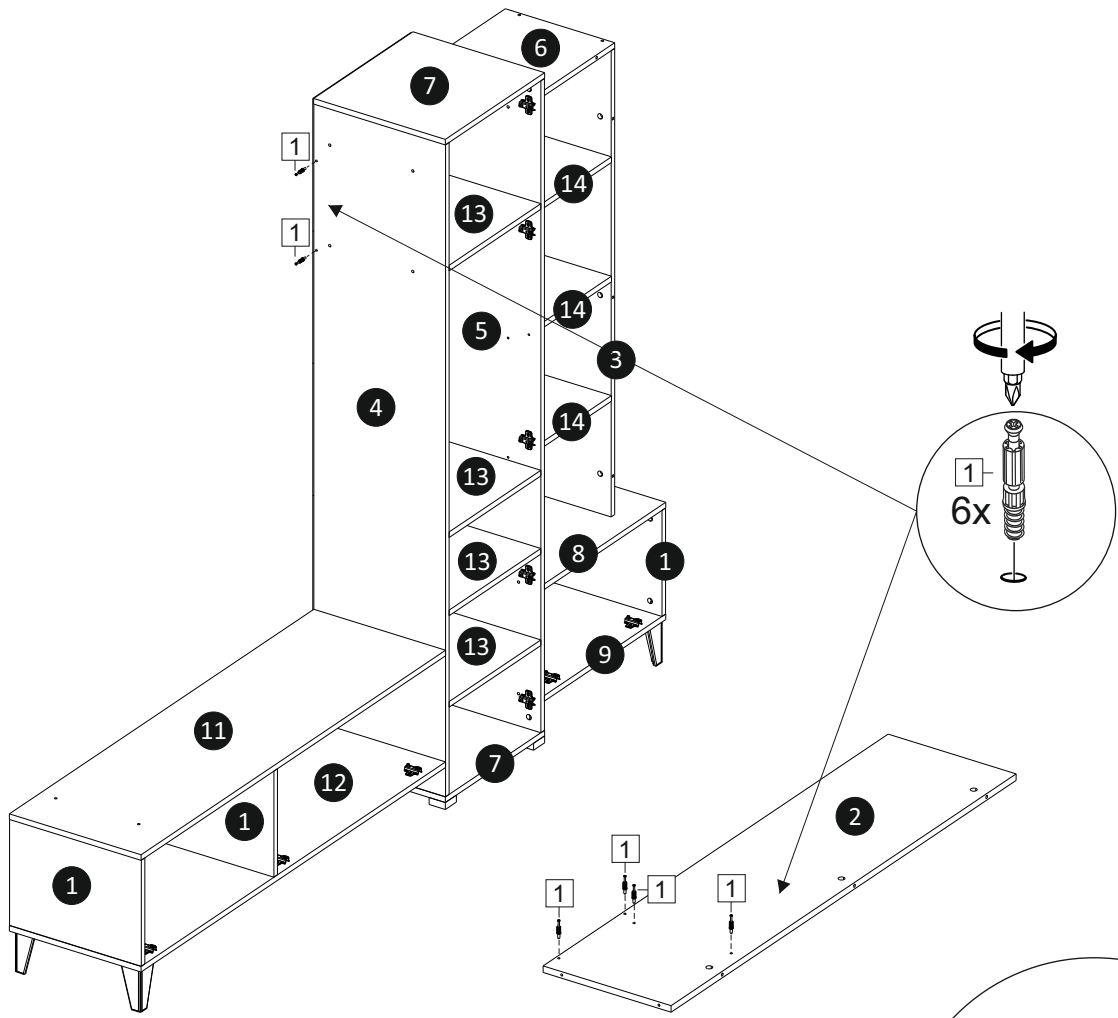

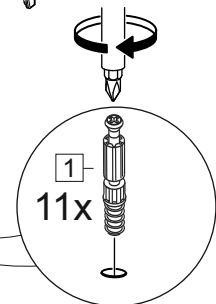
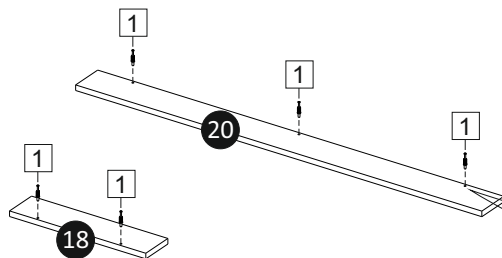
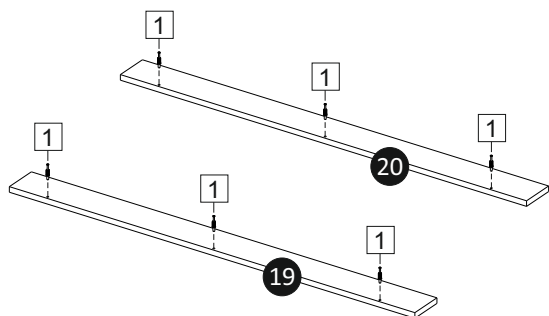
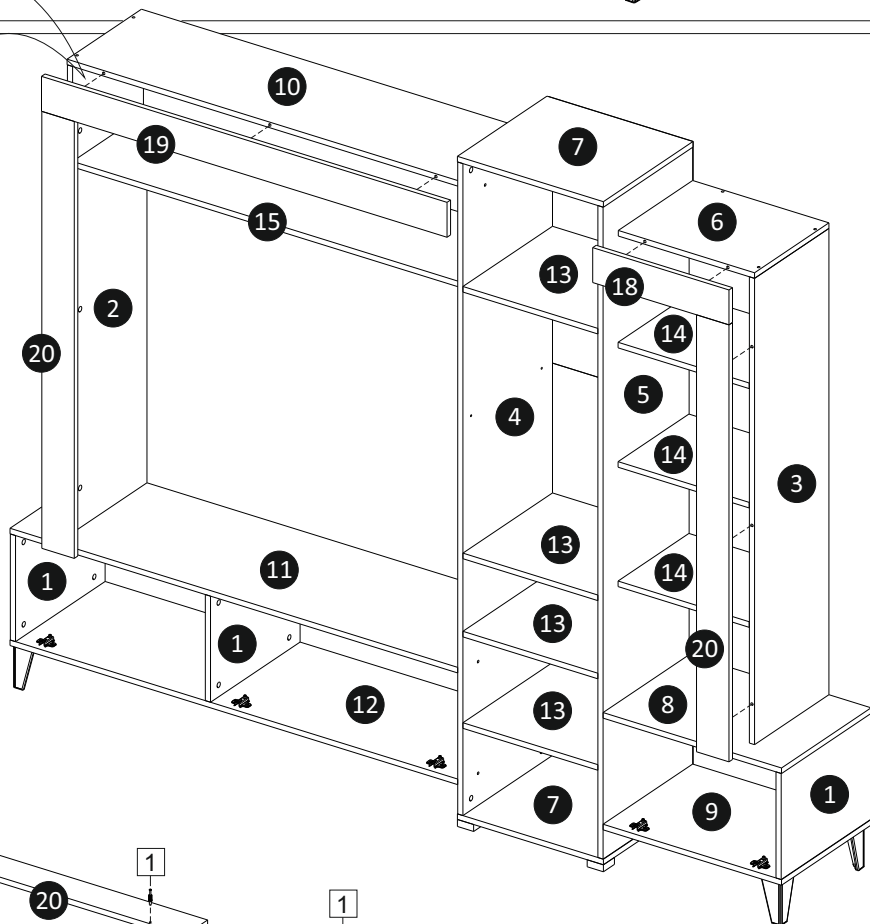
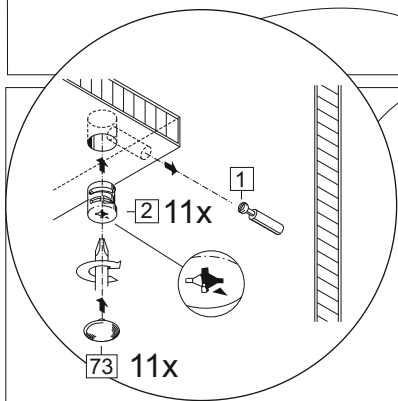
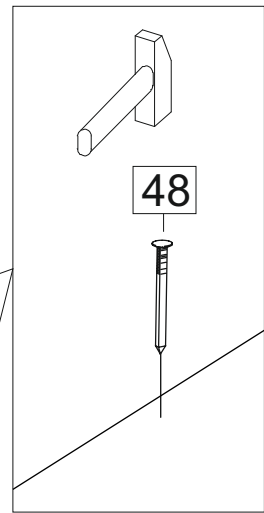
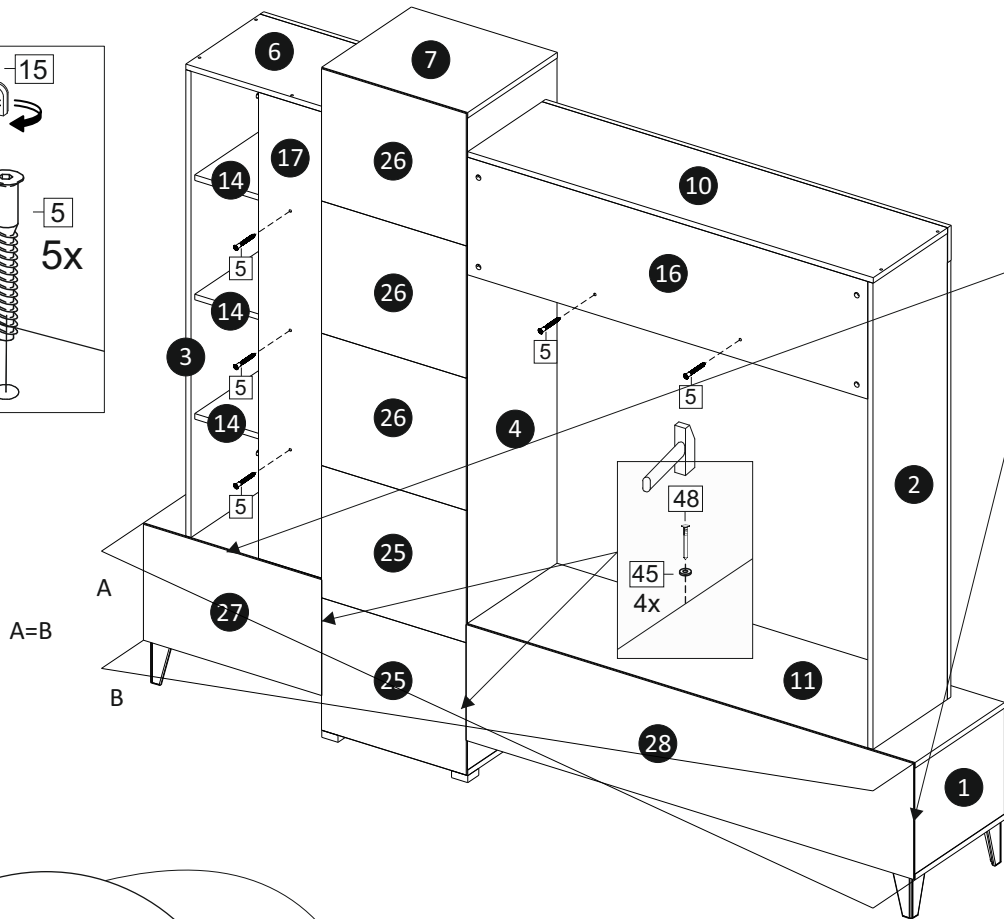
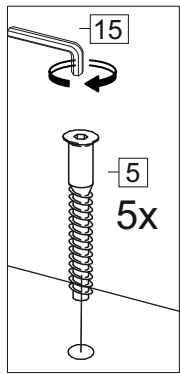

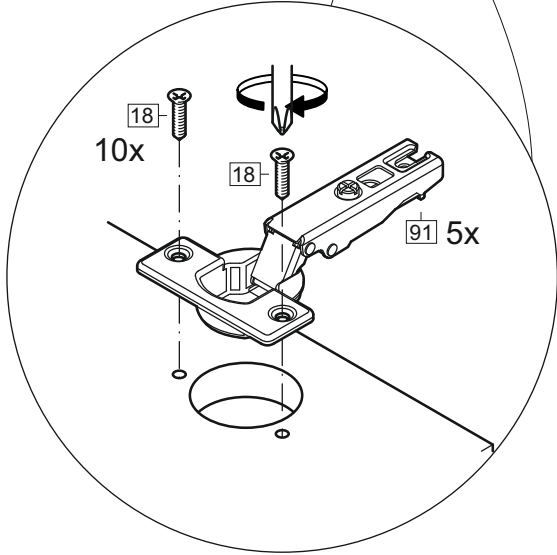
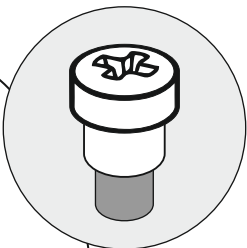
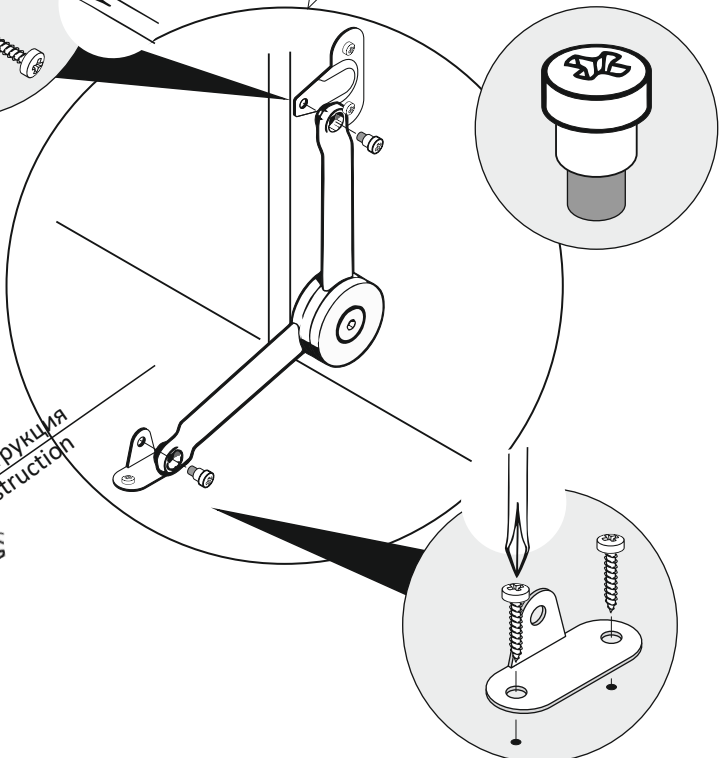
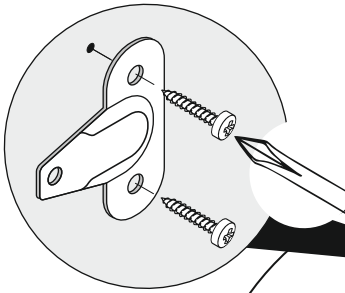
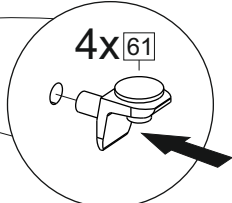
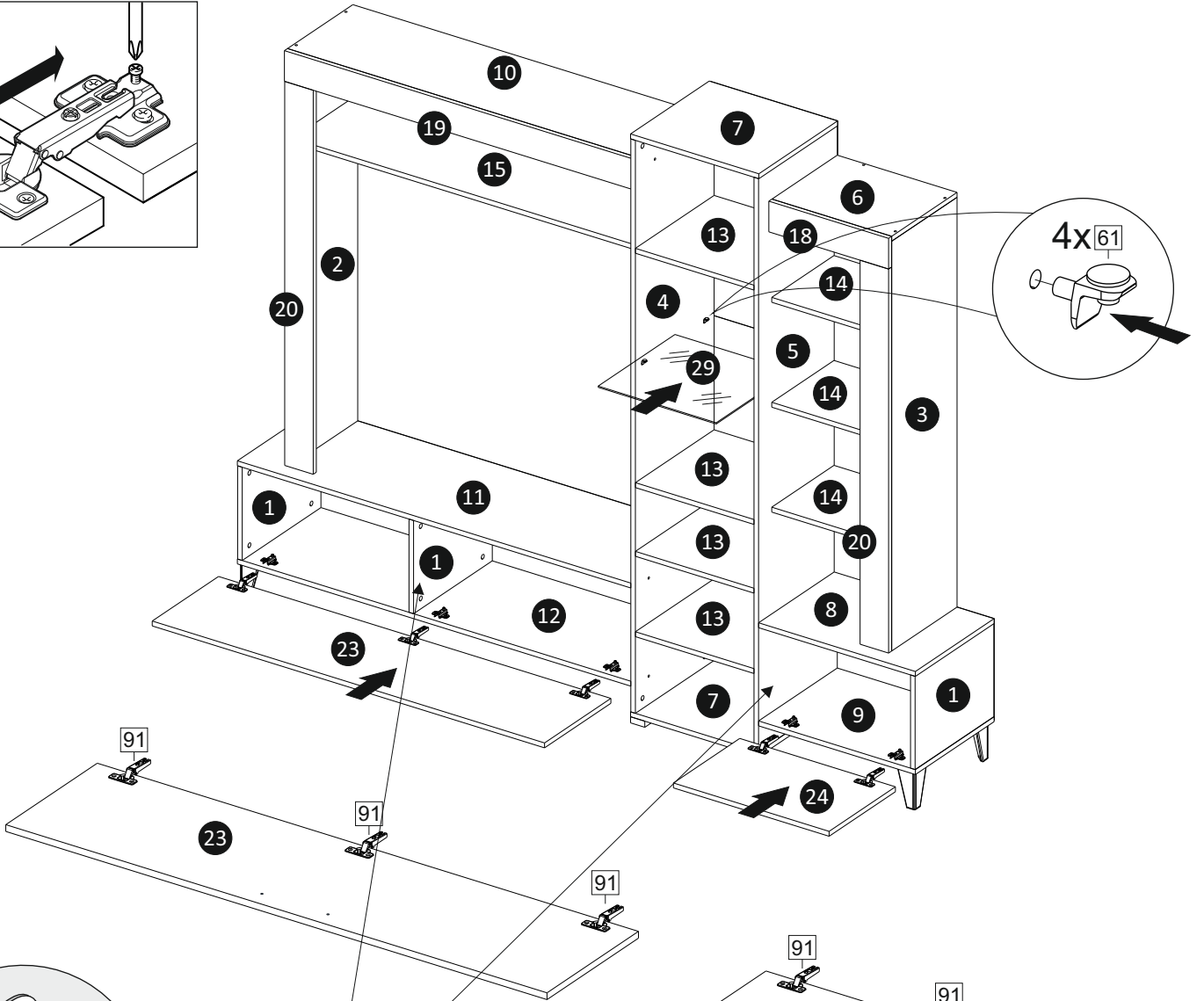
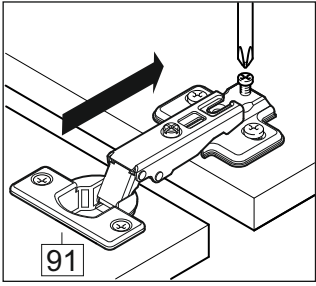

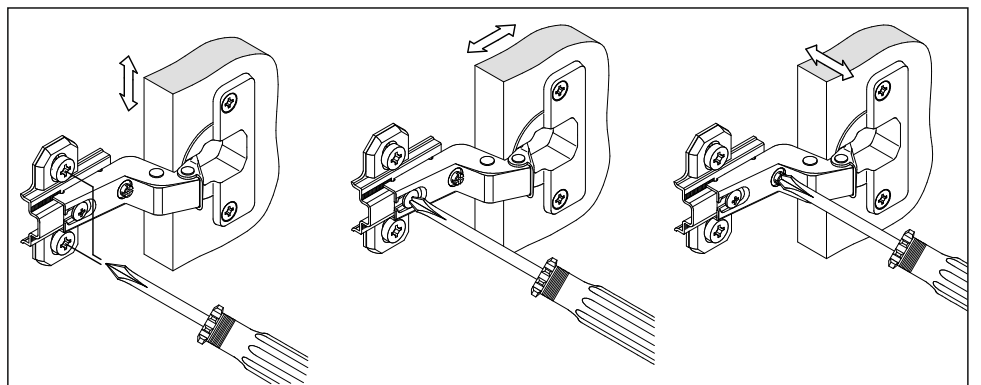
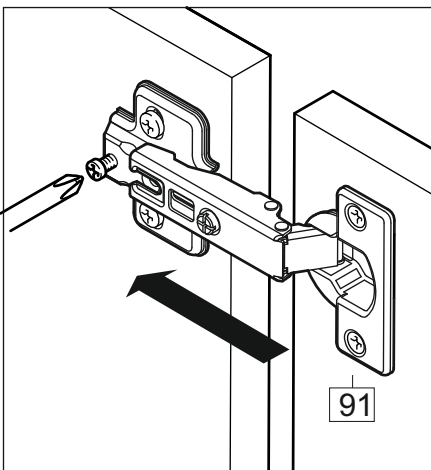
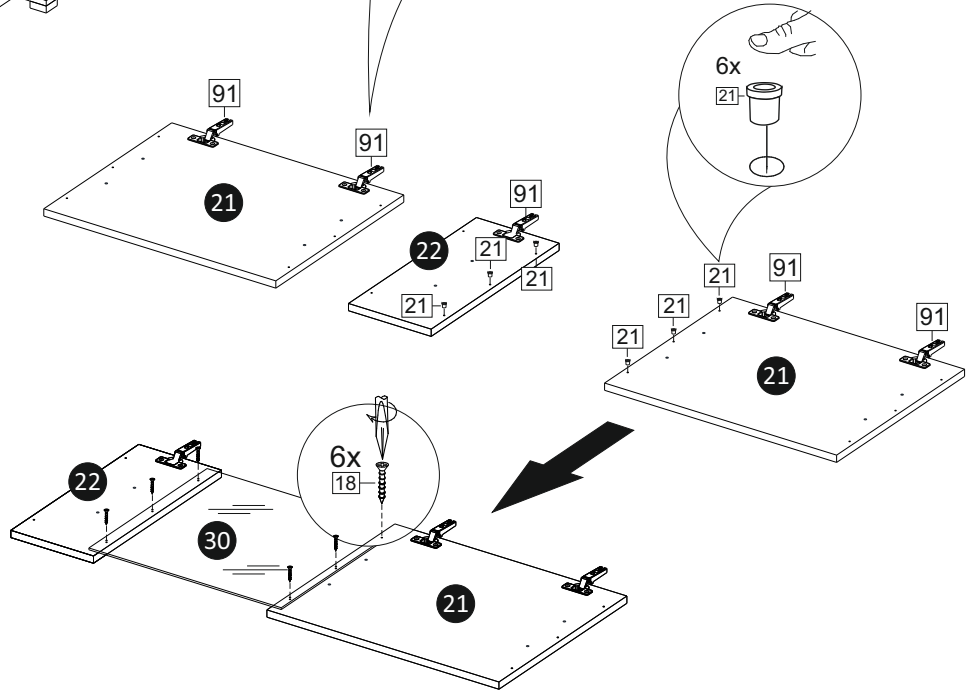
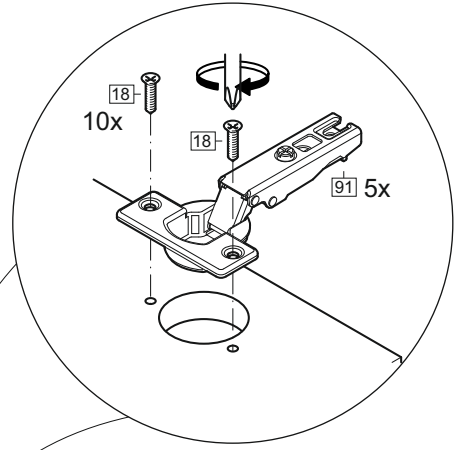
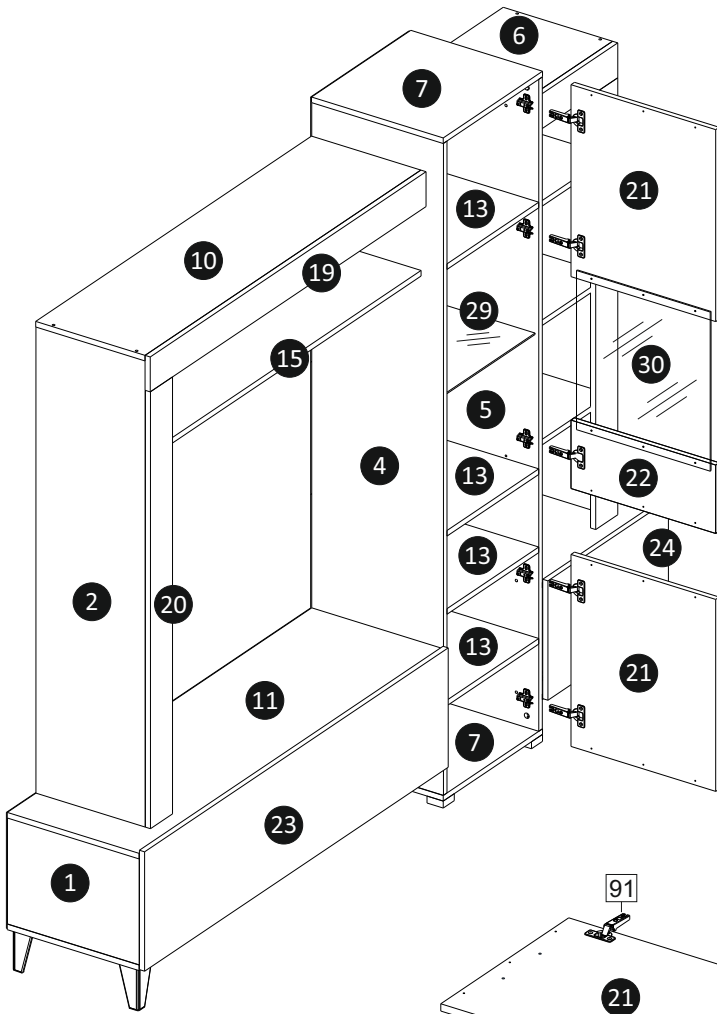

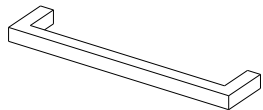

4 x

